

## *NavChip™* *Precision 6-Axis MEMS Inertial Measurement Unit*



### GENERAL DESCRIPTION

The NavChip™ is a high precision MEMS 6-axis inertial measurement unit (IMU). Using proprietary MEMS technologies and advanced signal processing techniques, the NavChip achieves a level of performance, miniaturization, and environmental ruggedness superior to other IMUs of its size.

The NavChip is especially well-suited for embedded applications where extremely small size, low cost, and low power consumption are required. It is fully factory-calibrated and temperature compensated over an operating range of -40°C to +85°C.

### APPLICATIONS

Augmented and Virtual Reality

Unmanned Systems

Robotics

Camera & Antenna Stabilization

Pedestrian Navigation

GPS/INS Integration

Aiming & Alignment

### FEATURES

- Fully-compensated  $\Delta\Theta$  and  $\Delta V$  outputs
- Gyro bias in-run stability 5°/hr
- Angular random walk 0.18°/√hr
- Velocity random walk 0.03m/s/√hr
- Full-scale angular rate of 2000°/s
- Full-scale acceleration of  $\pm 16g$
- Low power consumption 135mW
- Selectable built-in test (BIT) modes for commanded and continuous diagnostic monitoring
- Factory calibrated bias, scale factor and misalignment (-40°C to +85°C)
- TTL UART or SPI-compatible data output interfaces
- Embedded temperature sensors
- Selectable output data types and rates
- External sync pin can accept optional GPS pulse-per-second or faster synchronization signal
- Single supply operation 3.25V to 5.5V
- Small 12.5 x 24.5 x 5.4 mm
- Lightweight 3 g
- Evaluation adapter boards available

**ABSOLUTE MAXIMUM RATINGS**

Vdd to GND.....-0.3V to +6.0V  
 Dig In/Out Voltage to GND.....-0.3V to +3.3V  
 Analog Inputs to GND.....-0.3V to +3.3V  
 Operating Temperature Range....-40°C to +85°C  
 Storage Temperature Range.....-40°C to +85°C

*Stresses beyond those listed under “Absolute Maximum Ratings” may cause permanent damage to the device. Functional operation of the device at these or any other conditions beyond those indicated in the operational section of this specification is not implied. Exposure to absolute maximum rating conditions for extended periods may affect device reliability.*

**ESD CAUTION**

**ESD (electrostatic discharge) sensitive device.**  
 Charged devices and circuit boards can discharge without detection. Although this product features patented or proprietary protection circuitry, damage may occur on devices subjected to high energy ESD. Therefore, proper ESD precautions should be taken to avoid performance degradation or loss of functionality.

**GYROSCOPE PERFORMANCE** (3.3V, +25°C, unless otherwise specified)

PARAMETER	TYP <sup>1</sup>	MAX <sup>2</sup>	UNITS
Full Scale Range	± 2000		°/s
In-Run Bias Stability (Allan Variance)	5	10	°/hr
Bias Accuracy over Operating Temp Range	± 0.2	± 0.4	°/s
g Sensitive Bias	0.004	0.03	°/s/g
Scale Factor Accuracy over Operating Temp Range	± 0.05	± 0.4	%
Scale Factor Linearity <sup>3</sup>	0.01	0.05	%
Angle Random Walk	0.18	0.3	°/√hr
Axis Mutual Alignment Accuracy	± 0.03	± 0.2	degrees

**ACCELEROMETER PERFORMANCE** (3.3V, +25°C, unless otherwise specified)

PARAMETER	TYP	MAX	UNITS
Full Scale Range	± 16		g
In-Run Bias Stability (Allan Variance)	0.04	0.1	mg
Bias Accuracy over Operating Temp Range	± 3	± 15	mg
Scale Factor Accuracy over Operating Temp Range	± 0.09	± 0.2	%
Scale Factor Linearity <sup>4</sup>	0.06	0.2	%
Velocity Random Walk	0.03	0.05	m/s/√hr
Axis Mutual Alignment Accuracy	± 0.03	± 0.2	degrees

<sup>1</sup> TYP Specs are mean values or 1σ for values that are nominally zero.

<sup>2</sup> MAX Specs are maximum factory test limits unless otherwise specified.

<sup>3</sup> Factory test up to 810 °/s

<sup>4</sup> Factory test over ± 1g

**DIGITAL INPUTS/OUTPUTS**

PARAMETER	MIN	TYP	MAX	UNITS
Logic "0" Input Voltage	0		0.6	V
Logic "1" Input Voltage	2.1		3	V
Logic "0" Output Voltage		0	0.4	V
Logic "1" Output Voltage	2.4	3		V
Logic "0" Input Current		± 2		µA
Logic "1" Input Current		± 2		µA
Input Capacitance		10		pF

**TEMPERATURE SENSOR PERFORMANCE**

PARAMETER	MIN	TYP	MAX	UNITS
Temperature Sensing Range	-40		+85	°C
Resolution		0.05		°C
Accuracy		± 2.5	± 3.5	°C
Repeatability		± 0.5		°C

**FLASH MEMORY**

PARAMETER	Nominal	UNITS
Endurance	10,000	Cycles
Data Retention	20	Years

**TIMING**

PARAMETER	Nominal	UNITS
Power-on Startup (including 0.5s bootloader timeout)	< 1.0	Seconds
Built In Test Time (commanded TBIT)	< 2.0	Seconds

**PHYSICAL**

PARAMETER	Nominal	UNITS
Size (Including interconnect stack height)	12.5 x 24.5 x 5.4	mm
Weight	3	grams
RoHS Compliant	Yes	-

**ELECTRICAL**

PARAMETER	SYMBOL	CONDITIONS	MIN	TYP	MAX	UNITS
Supply Voltage Range	Vdd		3.25	3.3	5.5	V
Supply Current	Idd	after startup		40		mA
Internal power supply decoupling capacitance				200		µF

**UART INTERFACE**

PARAMETER	MIN	TYP	MAX	UNITS
Baud rate	38,400	115,200	921,600	Bits per second
Baud rate deviation from nominal	-1.5	± 0.2	1.5	%
8 data bits, 1 start bit, no parity				

## FUNCTIONAL DESCRIPTION

The NavChip is a miniature precision IMU which outputs compensated  $\Delta\Theta$  and  $\Delta V$  data and is factory calibrated over a  $-40^{\circ}\text{C}$  to  $+85^{\circ}\text{C}$  temperature range.

The command and data interface occurs through either a 3V TTL UART or a standard SPI interface. The UART is capable of operating at baud rates ranging from 38400 baud up to 921600 baud. Both interfaces support user-selectable packet transmission rates up to 200 Hz. Communication with the NavChip is through a packet-based protocol which allows the user to configure the device and receive data and device status. See the NavChip Interface Control Document (ICD) for details on the operation of these interfaces.

Internally, the NavChip performs data acquisition and processing at a precise 1 kHz rate. The data is integrated down to a 200 Hz (or lower) user-selectable rate, and compensation is performed to correct the sensors' biases, scale factors, misalignments, etc. By default, data packets are transmitted at 200 Hz (5 msec period), but a user may change the output period to other higher multiples of the 1 kHz internal rate, as explained in the ICD, to select lower output rates such as 100 Hz, 50 Hz, etc.

Optionally, rather than using the internal 1 kHz clock, the NavChip's internal sampling may be synchronized to a precision external clock reference, such as a GPS pulse-per-second (PPS) signal. Any periodic signal whose period is an integer number of milliseconds between 1 and 1000 can be used for synchronization. Refer to the ICD for timing diagram and details on how to configure NavChip for external synchronization.

Factory calibration corrects for misalignments between the sensor axes, resulting in measurement axes that are highly orthogonal to one another. However, the alignment of these IMU "intrinsic" axes relative to a host platform (such as a robot, UAV or camera) will be affected by the precision of the mounting of the NavChip onto the mating board and also the mounting of the mating board in the host platform.

To allow customers to compensate for "extrinsic" misalignment angles (the rotation between the intrinsic axes and the host platform), the NavChip provides registers for programming a boresight matrix which rotates the  $\Delta\Theta$  and  $\Delta V$  vectors from the NavChip's internal (intrinsic) reference frame to the vehicle's body frame. An extrinsic calibration tool is available which will allow the user to determine the boresight matrix relative to a reference jig having two orthogonal surfaces, and load it into the NavChip.

The acceleration measurements are computed relative to a coordinate origin point at 1.5mm below the center of the bottom surface of NavChip (i.e. the center of the NavChip footprint on the mating board).

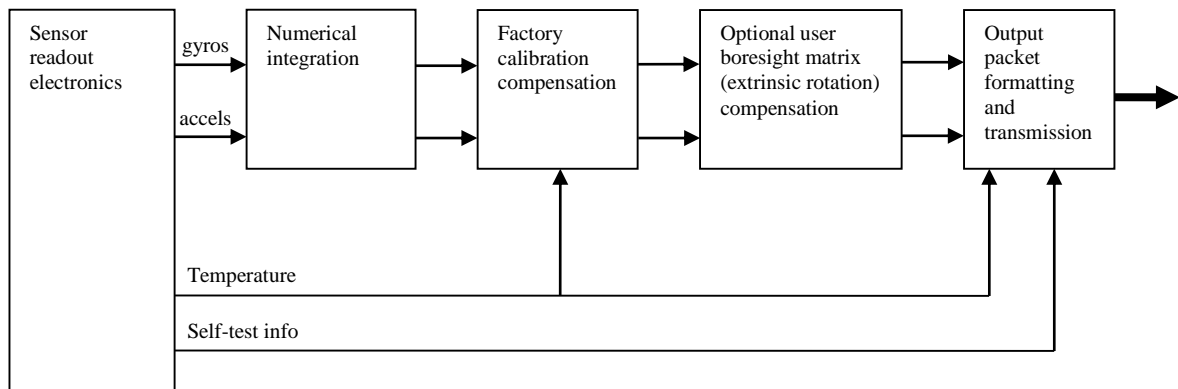

**Figure 1: Functional block diagram**

## Mechanical Dimensions

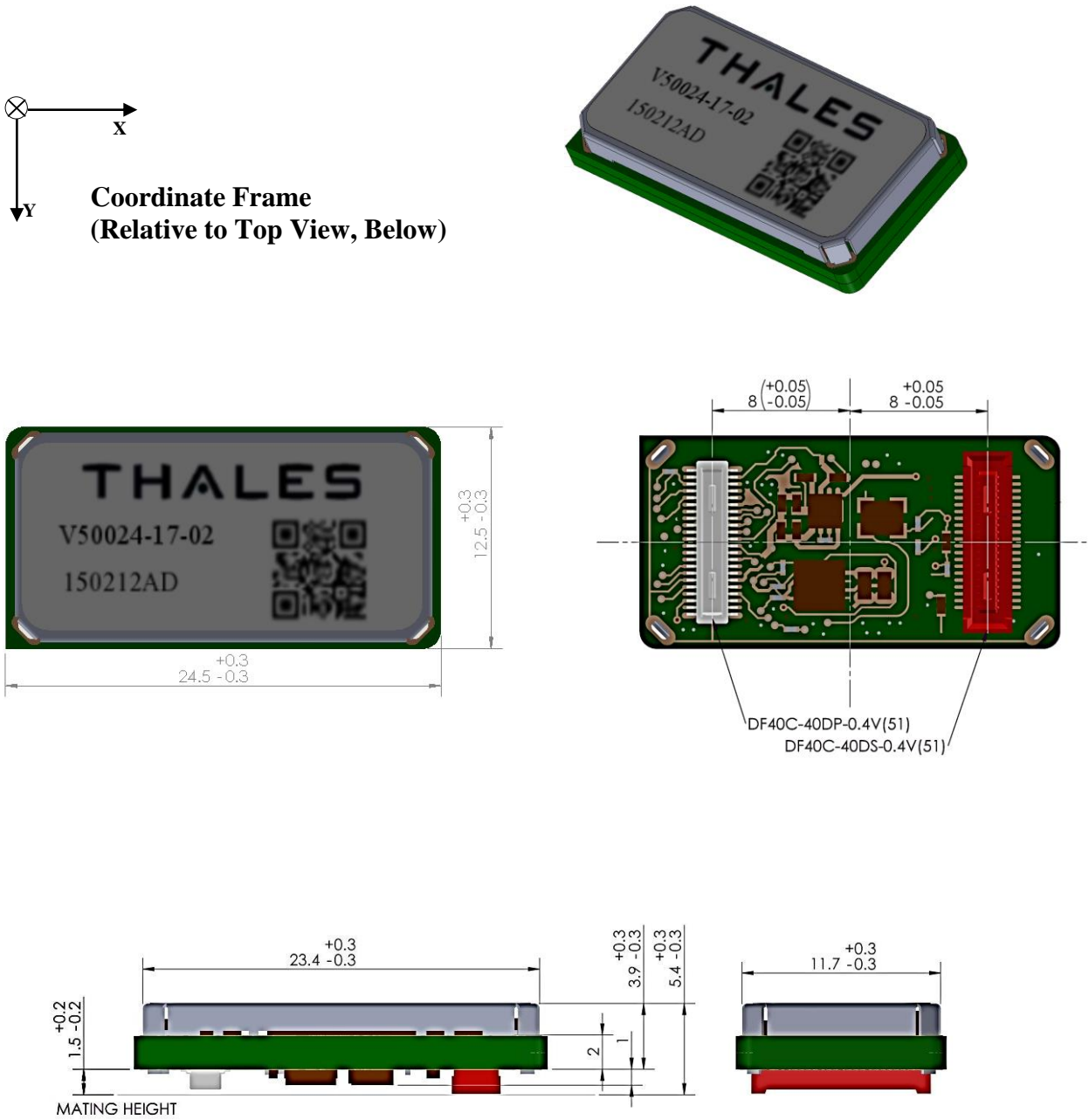

Figure 2: NavChip Mechanical dimensions

## Interface Description

The NavChip has two high density, high contact reliability, interface connectors which allows users to design the device directly into their system. The two connectors, designated “P1” and “J1”, have different genders to avoid mis-assembly when plugging the NavChip in.

Connector “J1” is a 40-pin interconnect that is used to supply ground to the NavChip’s RF shield; otherwise this connector is used as a secure mounting feature.

Connector “P1” is a 40-pin interconnect that carries all other electrical interfaces between the NavChip and the user’s board. Please note, P1 actually has 44 pins; the outermost 4 pins are used for structural support only and do not carry any signals. Refer to Figure 4 below for more information regarding the pin numbering.

**IMPORTANT: DO NOT CONNECT ANY SIGNALS TO THE NC PINS. DOING SO MAY DAMAGE THE NAVCHIP OR CAUSE IT TO MALFUNCTION.**

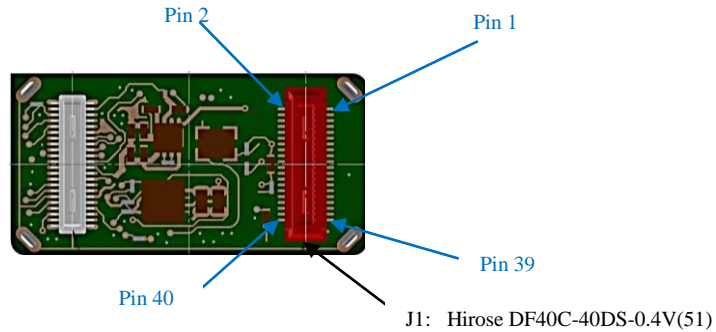

**Figure 3: J1 Connector**

**Table 1: J1 Pin Functional Descriptions**

PIN	PIN NAME	PIN TYPE	PIN DESCRIPTION
1	GND	Ground	Power Ground
2	GND	Ground	Power Ground
3-38	NC	-	Reserved for Factory Use
39	GND	Ground	Power Ground
40	GND	Ground	Power Ground

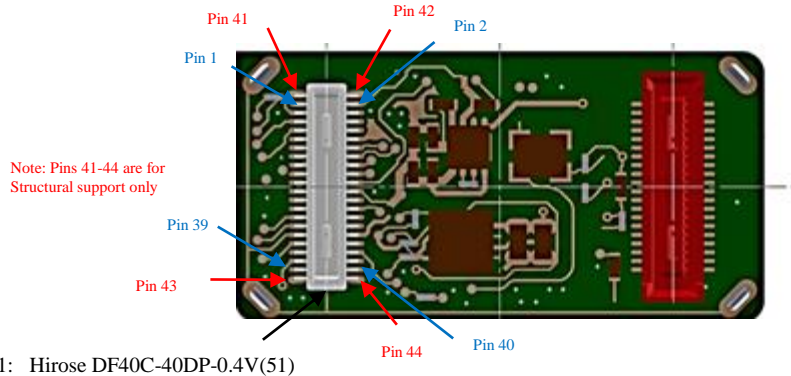

Figure 4: P1 Connector

Table 2: P1 Pin Functional Descriptions

\*Please note that the four corner pins are non-functional pins and are not included in the following table.

PIN	PIN NAME	PIN TYPE	PIN DESCRIPTION
1	Vlogic	Output	3V logic reference output (25mA max.)
2	Vlogic	Output	3V logic reference output
3-8	NC	-	Reserved for Factory Use
9-10	GND	Ground	Power/Ground
11	SPI_SCK	Input	CLK
12	SPI_SCK	Input	CLK
13	SPI_SDO	Output	MISO
14	SPI_SDO	Output	MISO
15	SPI_SDI	Input	MOSI
16	SPI_SDI	Input	MOSI
17	NC	-	Reserved for Factory Use
18	NC	-	Reserved for Factory Use
19	NC	-	Reserved for Factory Use
20	NC	-	Reserved for Factory Use
21	NC	-	Reserved for Factory Use
22	Vin	Power	3.25V to 5.5V
23-24	NC	-	Reserved for Factory Use
25	TTL_RX	Input	UART receiver
26	TTL_RX	Input	UART receiver
27	TTL_TX	Output	UART Transmitter
28	TTL_TX	Output	UART Transmitter
29	SYNC	Input	TTL sync input to external rising edge signal
30	SYNC	Input	TTL sync input to external rising edge signal
31	GND	Ground	Power/Ground
32	Vin	Power	3.25V to 5.5V
33	NC	-	Reserved for Factory Use
34	NC	-	Reserved for Factory Use
35	DRDY	Output	Data Ready
36	DRDY	Output	Data Ready
37	SPI_CS	Input	/CS
38	SPI_CS	Input	/CS
39-40	GND	Ground	Power/Ground

\*Note: It is recommended to connect identical signals across connector

## Mounting Recommendations for NavChip

The NavChip is designed to allow an end user the ability to integrate the device directly into their circuit card. Two high performance interface connectors allow the user to easily install the NavChip while assuring excellent performance from the device.

Please follow these layout guidelines for optimal performance in your application:

1. Refer to Figure 2: NavChip Mechanical Dimensions for clearances required for proper mounting.
2. It is recommended that no components are placed under the NavChip
3. Separation and alignment of the connector footprint is critical. Variance from the specified 8mm separation will induce un-calibrated stresses into the NavChip and may effect performance
4. Connectors are high retention strength so please use care when separating the NavChip from the mating connectors. It is important to subject both ends of the device to equal force when removing it.
5. Only handle the NavChip in an ESD controlled environment. Proper ESD guidelines (i.e. a grounded strap) should be used when handling the device.

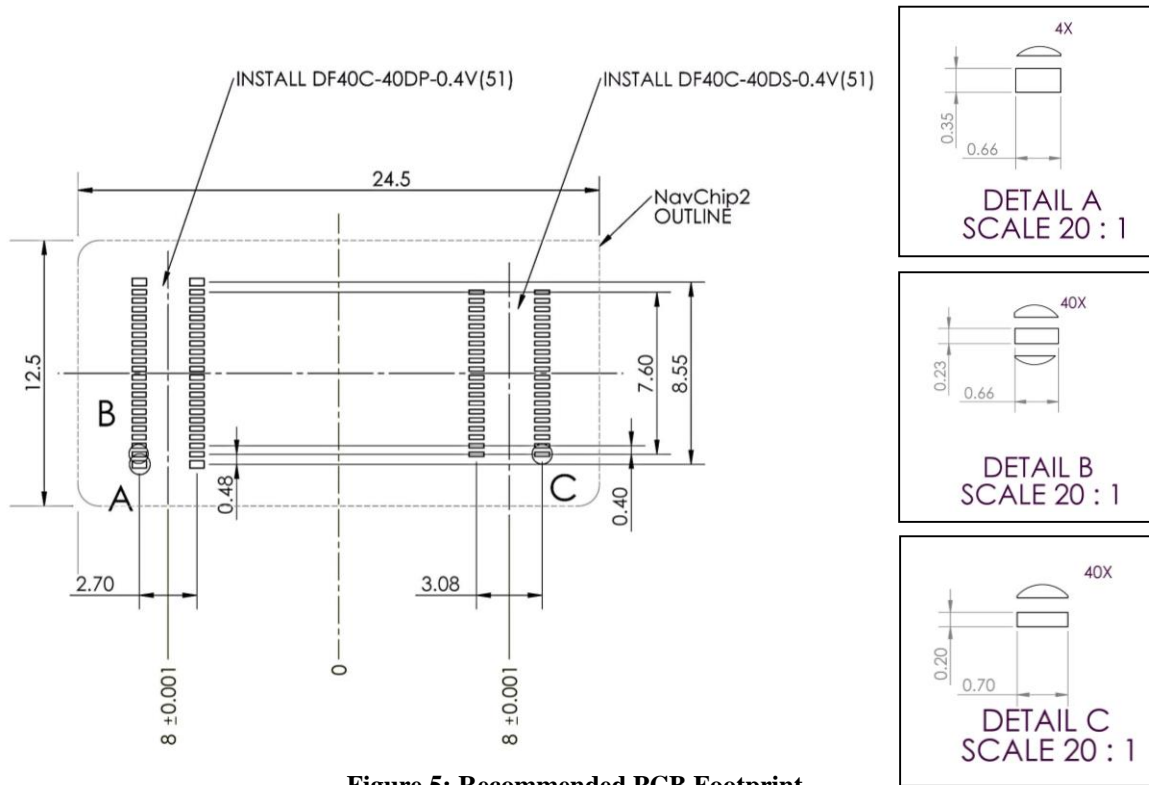
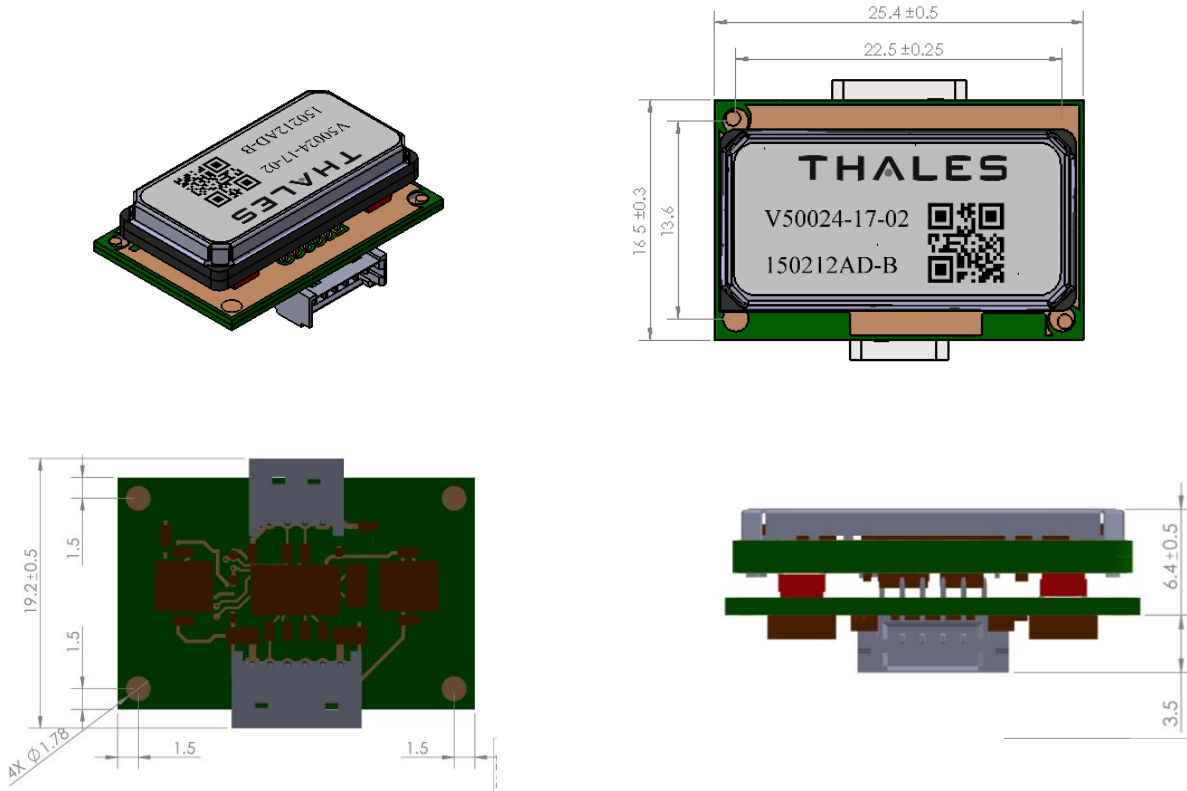

**Figure 5: Recommended PCB Footprint**



## The NavChip RS-422 Adapter Board Options

To simplify the evaluation or design integration of the NavChip into a user’s system, Thales Visionix offers several adapter boards with various standard interfaces. The RS-422 adapter board is a miniature circuit card assembly that has a slightly larger footprint than the NavChip. The RS-422 adapter board has mating connectors for the NavChip interface, an RS-422 level-shifter, on-board regulation, and four holes to securely mount the assembly into a system while allowing wired connectivity to a host board. The RS-422 link interfaces through a high friction Molex connector which will allow users to fabricate their own interface cable.



**Figure 6: RS-422 Adapter Board Mechanical Dimensions (with NavChip installed)**

**Table 3: RS-422 Adapter Board Pin Descriptions**

Connector Type: Molex 53048-0610

PIN	PIN NAME	PIN TYPE	PIN DESCRIPTION
1	Vdd	Power	+5Vdc to +12Vdc
2	RX+	Input (digital)	UART receive input
3	RX-	Input (digital)	UART receive input
4	TX-	Output (digital)	UART transmit output
5	TX+	Output (digital)	UART transmit output
6	GND	Ground	Power Ground

## The NavChip USB/TTL Serial Evaluation Board

This adapter board features a Micro-B USB interconnect to simplify setup for evaluation or integration of the NavChip. The adapter board can interface through either the Micro-USB or through an on board Molex connector, allowing for a high retention USB interconnect if required.

The USB / TTL Serial Adapter board can also be configured for TTL serial through on board jumpers. The TTL serial interface will only be available through the Molex connector.

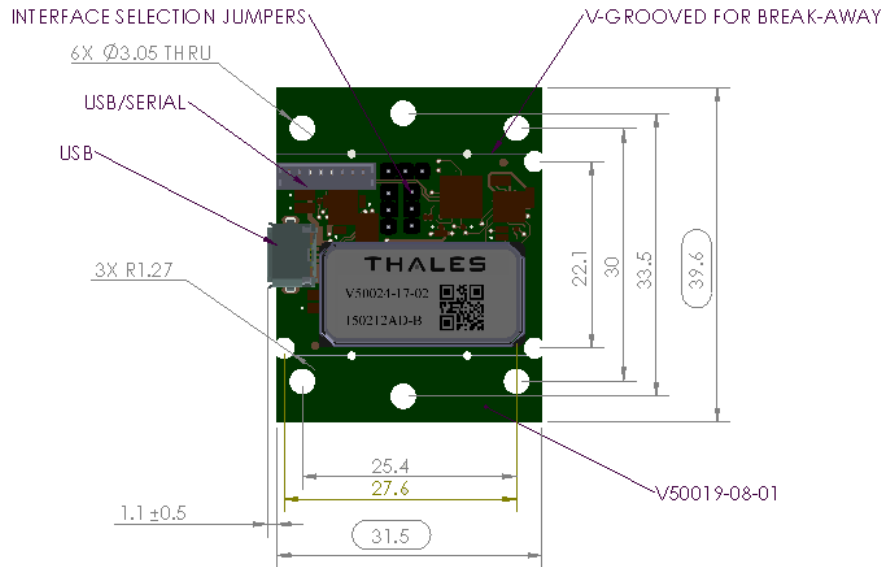

**Figure 7: USB/TTL Serial Adapter Board Mechanical Dimensions (with NavChip installed)**

**Table 4: (J3) USB/ TTL Interface Descriptions**

Connector Type: Molex 53048-0810

PIN	PIN NAME	PIN TYPE	PIN DESCRIPTION
1	USB D+	Digital	Bi-Directional USB data
2	USB D-	Digital	Bi-Directional USB data
3	VDD	Power	Power for TTL Serial Mode
4	RX	Input (digital)	TTL Serial UART Input
5	TX	Output (digital)	TTL Serial UART Output
6	GND	Ground	Power Ground
7	SYNC	Input	TTL sync input to external rising edge signal
8	USB 5V	Power	Power for USB Mode

**J3**, Molex [53047-0810](#), PicoBlade connector. Mates with Molex [51021-0800](#). See Molex webpage for crimp terminals.

**Table 5: USB/ TTL Interface Selection Jumpers**

<b>JUMPER CONFIGURATION</b>		
	<b>TTL</b>	<b>USB (DEFAULT)</b>
<b>J5</b>	1-2	2-3
<b>J6</b>	1-2	2-3
<b>J7</b>	1-2	2-3



**Figure 8: Evaluation Kit Contents**

## The NavChip Samtec/ADIS Adapter Kit

This adapter kit contains all of the necessary interface hardware needed to make the NavChip sensor compatible with the mounting scheme and connectivity of the ADIS family of IMU sensors.

The kit contains the main adapter board, for mounting your NavChip IMU, along with a daughter board that includes of the same Samtec connector that ADIS utilizes making this a “socket compatible” solution. A 2 inch flex cable that connects the daughter board to the main board is provided. If a user elects to fabricate their own cable to mount the NavChip away from the daughter board, however, the NavChip interfaces are TTL-level signals so it is recommended that cable lengths be no longer than 10 inches.

The NavChip Samtec/ADIS Kit is signal compatible with the ADIS interface. Additionally, the adapter kit also offers a serial UART interface to pins that the ADIS sensor defines as “no connect”. Please note that the NavChip API differs from the ADIS protocol.

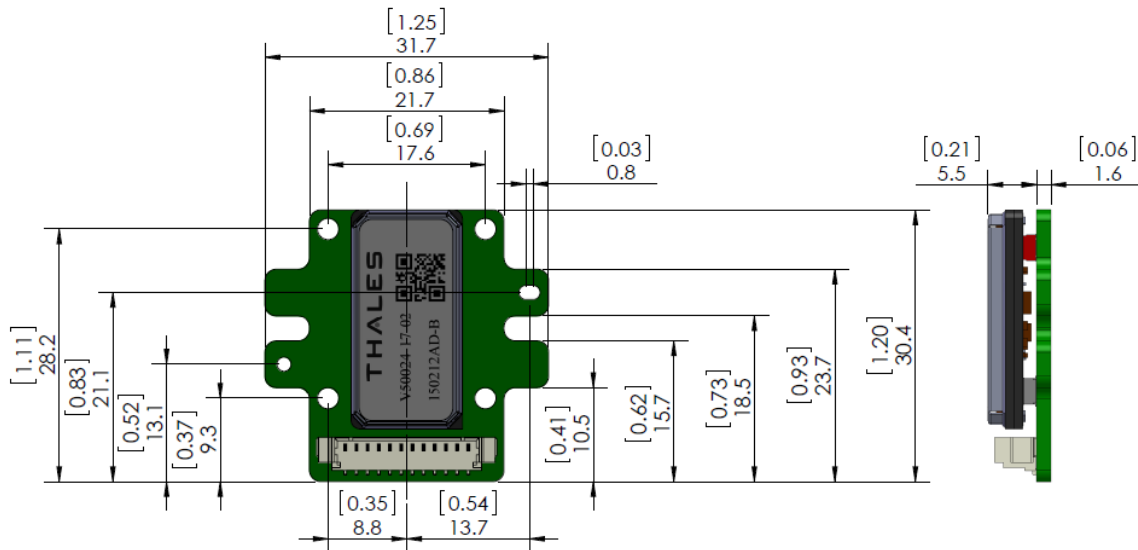

**Figure 9: NavChip Samtec/ADIS Main Board Mechanical Dimensions**

**Table 5: NavChip Samtec/ADIS Main Board Pin Descriptions:**  
Connector type: Molex 53398-1271

PIN	PIN NAME	PIN TYPE	PIN DESCRIPTION
1	Vdd	Power	
2	RX	Input (digital)	UART receive input
3	TX	Output (digital)	UART transmit output
4	GND	Ground	Power Ground
5	SYNC	Input (digital)	Optional digital sync input
6	SPI_SCK	Input (digital)	SPI serial clock input
7	SPI_SDO	Output (digital)	SPI data output
8	SPI_SDI	Input (digital)	SPI data input
9	NC	-	Reserved for Factory Use
10	SPI_DR	Output (digital)	SPI data ready output
11	SPI_CS	Input (digital)	SPI chip select input
12	V <sub>LOGIC</sub>	Output	3V logic reference output (25mA max.)

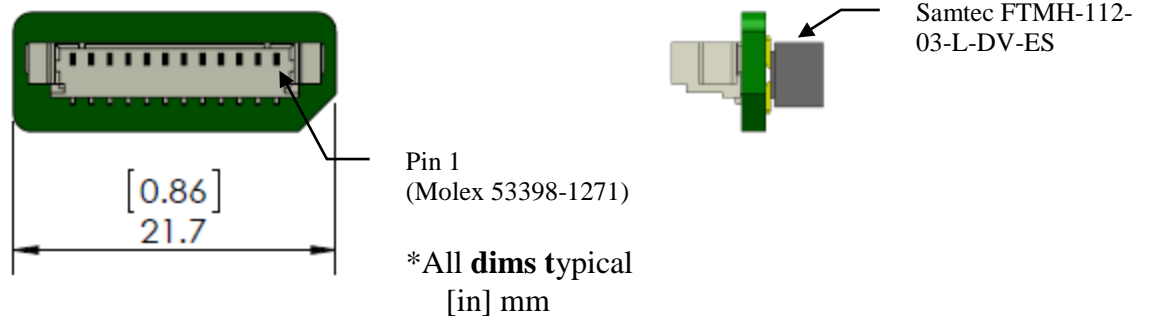

**Figure 10: NavChip Samtec/ADIS Daughter Board Mechanical Dimensions**

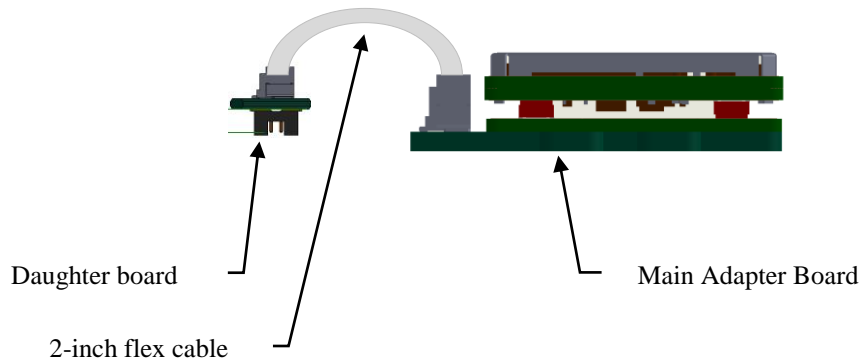

**Figure 10: NavChip Samtec/ADIS Kit full assembly**

**Table 6: NavChip Samtec/ADIS Daughter Board Interface Pin Descriptions:**

Connector type: Molex 53398-1271

PIN	PIN NAME	PIN TYPE	PIN DESCRIPTION
1	Vdd	Power	
2	RX	Input (digital)	UART receive input
3	TX	Output (digital)	UART transmit output
4	GND	Ground	Power Ground
5	SYNC	Input (digital)	Optional digital sync input
6	SPI_SCK	Input (digital)	SPI serial clock input
7	SPI_SDO	Output (digital)	SPI data output
8	SPI_SDI	Input (digital)	SPI data input
9	NC	-	Reserved for Factory Use
10	SPI_DR	Output (digital)	SPI data ready output
11	SPI_CS	Input (digital)	SPI chip select input
12	V <sub>LOGIC</sub>	Output	3V logic reference output (25mA max.)

**Table 7: NavChip Samtec/ADIS Daughter Board Interface Pin Descriptions:**

Connector type: Samtec FTMH-112-03-L-DV-ES

PIN	PIN NAME	PIN TYPE	PIN DESCRIPTION
1	NC	-	Reserved for Factory Use
2	NC	-	Reserved for Factory Use
3	SPI_SCK	Input (digital)	SPI serial clock input
4	SPI_SDO	Output (digital)	SPI data output
5	SPI_SDI	Input (digital)	SPI data input
6	SPI_CS	Input (digital)	SPI chip select input
7	NC	-	Reserved for Factory Use
8	NC	-	Reserved for Factory Use
9	NC	-	Reserved for Factory Use
10	Vdd	Power	
11	Vdd	Power	
12	Vdd	Power	
13	GND	Ground	Power Ground
14	GND	Ground	Power Ground
15	GND	Ground	Power Ground
16	SPI_DR	Output (digital)	SPI data ready output
17	NC	-	Reserved for Factory Use
18	NC	-	Reserved for Factory Use
19	V <sub>LOGIC</sub>	Output	3V logic reference output (25mA max.)
20	NC	-	Reserved for Factory Use
21	NC	-	Reserved for Factory Use
22	RX	Input (digital)	UART receive input
23	SYNC	Input (digital)	Optional digital sync input
24	TX	Output (digital)	UART transmit output

**ORDERING INFORMATION**

Please reference to the following part numbers when ordering your desired NavChip configuration.

NavChip

V50024-17-02: NavChip, 2000°/s, ± 16g

NavChip Adapter Boards (NavChip not included)

V14440-17-01: NavChip Adapter Board, USB/TTL

V14441-17-01: NavChip Adapter Board, RS-422

V14508-03-01: NavChip Adapter Board, Samtec/ADIS Adapter Kit

NavChip Evaluation Kit (Includes NavChip, adapter board, cable and case)

V14444-03-02: NavChip Evaluation Kit, USB/TTL, 2000°/s

V14447-03-02: NavChip Evaluation Kit, RS-422, 2000°/s

***Usage and liability disclaimer for Thales Visionix NavChip***

All Thales Visionix products are sold pursuant to Thales Visionix's terms and conditions of sale. Information furnished herein is believed to be accurate; however, no responsibility is assumed by Thales Visionix from its use or for any infringements of patents or other rights of third parties that may result from its use or the use of Thales Visionix products. Thales Visionix reserves the right to make changes, corrections, modifications or improvements to this document and to the products described herein at any time, without notice. Thales Visionix makes no warranty, representation or guarantee, either express or implied, regarding the information in this document or the suitability of its products for any particular purpose and specifically disclaims any and all liability, including without limitation consequential or incidental damages. Unless expressly indicated otherwise in a separate writing by Thales Visionix, no license is granted by implication or otherwise under any intellectual property right of Thales Visionix or any third party, including but not limited to any patent or patent rights, copyright or trademark rights.

**Thales Visionix products are not intended for any application in which the failure of the product could result in personal injury, death or severe property damage. Thales Visionix sensors should not be used or sold for use in any conventional or mass-destructive weapons or any other weapons or life-threatening applications, nor in safety-critical applications such as life-support equipment, transportation, aerospace and nuclear instruments, undersea equipment, or any other applications where unexpected behavior of the sensors could cause bodily harm.** Should Buyer purchase or use Thales Visionix products for any such unintended or unauthorized application, Buyer shall indemnify and hold Thales Visionix and its officers, employees, subsidiaries, affiliates, and distributors harmless against any and all claims, costs, damages, expenses, and reasonable legal fees arising out of, directly or indirectly, any claim of severe property damage, personal injury, bodily harm or death associated with such unintended or unauthorized use, even if such claim alleges that Thales Visionix was negligent regarding the design or manufacture of the part.



Resale of Thales Visionix products with provisions different from the statements and/or technical features set forth in this document shall immediately void any warranty granted by Thales Visionix for the Thales Visionix product or service described herein and shall not create or extend in any manner whatsoever, any liability of Thales Visionix. Thales Visionix and the Thales Visionix logo are trademarks or registered trademarks of Thales Visionix in various countries. Information in this document supersedes and replaces all information previously supplied. ©2016 Thales Visionix Incorporated. All rights reserved.

---

Contact us at +1 781 541 7650 or [Sales@thalesvisionix.com](mailto:Sales@thalesvisionix.com) for more details on using Thales Visionix technology or becoming a distribution partner

Thales Visionix Inc.  
700 Technology Park Drive  
Billerica, MA 01821 USA

T: +1 781 541 6330  
F: +1 781 541 6329  
[www.ThalesVisionix.com](http://www.ThalesVisionix.com)  
[www.InterSense.com](http://www.InterSense.com)